

MODEL 9060 UNIVERSAL AIR KNIFE MOUNTING SYSTEM **INSTALLATION & MAINTENANCE**



APPLICATIONS

The Universal Air Knife Mounting System is used to provide precise positioning of the air knife. It can be mounted on either the top or bottom of most air knives (Super Air Knife, Standard Air Knife and Full-Flow Air Knife). For Gen4 Super Ion Air Knives, it can be top mounted on any length. Bottom mounting is possible on Gen4 Super Ion Air Knives that are 18" (457mm) or longer. For Gen4 Standard Ion Air Knives, it can be top mounted on any length. Bottom mounting is possible on Gen4 Standard Ion Air Knives that are 9" (229mm) or longer.

For any style air knife that is 24" (610mm) to 54" (1372mm) use (2) Universal Air Knife Mounting Systems. For knives 55" (1397mm) – 71" (1803mm) use (3). For 72" (1829mm) – 95" (2413mm) use (4). For 96" (2438mm) and over use (5).

BRACKET INSTALLATION

Determine the best mounting position for the air knife and remove (3) adjacent screws as shown in Figure 1. While it is recommended to use the screws nearest the center of the air knife, it is not required. Place the bracket flat on the knife and align the holes (see Figure 1). For 3" (76mm) air knives, it may be necessary to use only (2) screws and allow the bracket to overhang the end of the air knife (see Figure 2). Install the new screws and washers (see Table 1 on page 3). Torque to 7.5 ft-lbs. For air knives that are assembled using screws and nuts, re-use the original nuts.

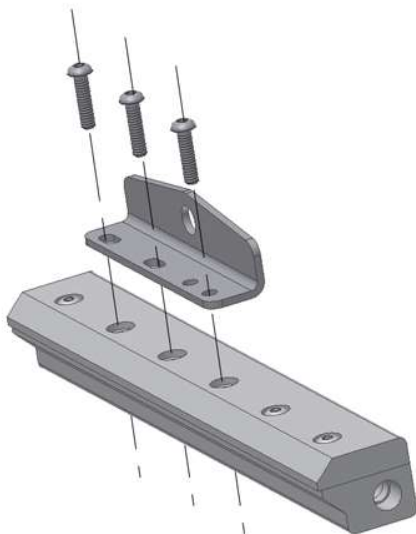

Figure 1 12" (305mm) Alum. Super Air Knife shown

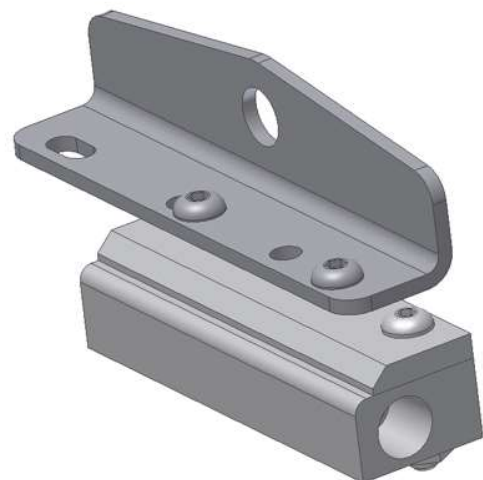

Figure 2 3" (76mm) St. Steel Standard Air Knife shown

Washers are required on Full-Flow Air Knives to ensure screws will not pull through the brackets (see Figure 3). Washers are also required when bottom mounting Stainless Steel Super Air Knives to avoid bottoming out the screws (see Figure 4).

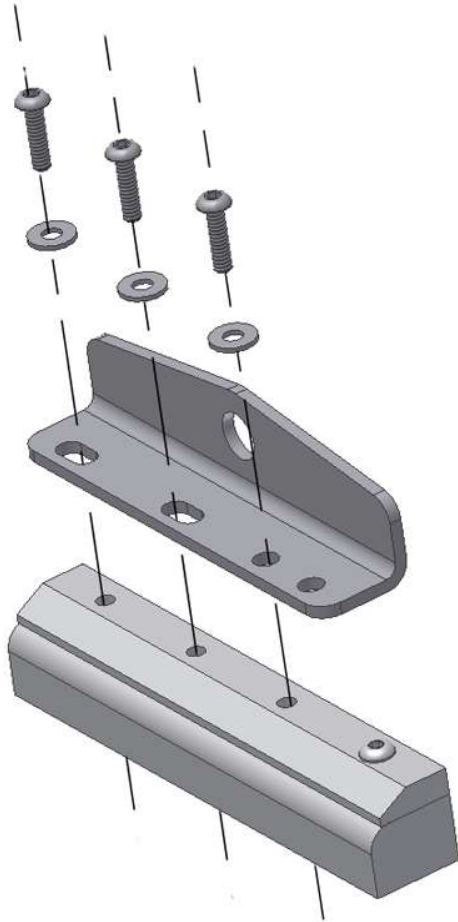

Figure 3 6" (152mm) Alum. Full-Flow Knife shown



Figure 4 9" (229mm) St. St. Super Air Knife shown

When bottom mounting Gen4 Standard Ion Air Knives, an open-end wrench must be used to remove and re-install the nuts from the bottom of the air knife. Once the screws are removed, the bracket can be slid in place and the new screws placed back in the holes. Re-use original nuts (see Figure 5).

For the 3" (76mm) Gen4 Standard Ion Air Knife - use one long screw on the end of the knife and one short screw in the middle. The bracket will overhang (see Figure 6).



Figure 5 12" (305mm) Gen4 Std Ion Air Knife shown

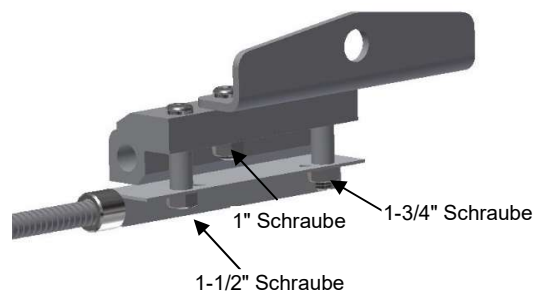

Figure 6 3" (76mm) Gen4 Std Ion Air Knife shown

Hardware size and mounting bracket position for all Air Knives

		Product								
		Length	Alum Super	SS Super	Alum Standard	SS Standard	Alum Full-Flow	SS Full-Flow	Gen4 Super IAK	Gen4 Standard IAK
Screw Size	¼ - 20	½	Bottom	Bottom						
		1	Top	Top	Top / Bottom				Bottom	
		1-½				Top / Bottom			Top	Top / Bottom
		1-¾								Top 3" & 6"
		Washer		Bottom						
	10 - 24	½					Bottom	Bottom		
		¾					Top	Top		
		Washer					Top / Bottom	Top / Bottom		

Table 1

EXTENSION BAR ASSEMBLY MOUNTING

Remove one nut and one lock washer from one end of extension bar assembly. Slide bolt into a 17/32" hole on an existing structure or machine frame. Place lock washer and nut back on the bolt and tighten to 60-100 ft-lbs (see Figure 7). Alternatively, the bolt can be threaded directly into a 1/2"-13 tapped hole.

On the opposite end of the assembly, remove one nut and one lock washer from the bolt. Place the bracketed air knife onto the bolt through the hole on the bracket. Place lock washer and nut back on the bolt and tighten it to 60-100 ft-lbs. The wing nuts can now be loosened and the assembly adjusted to the desired position.

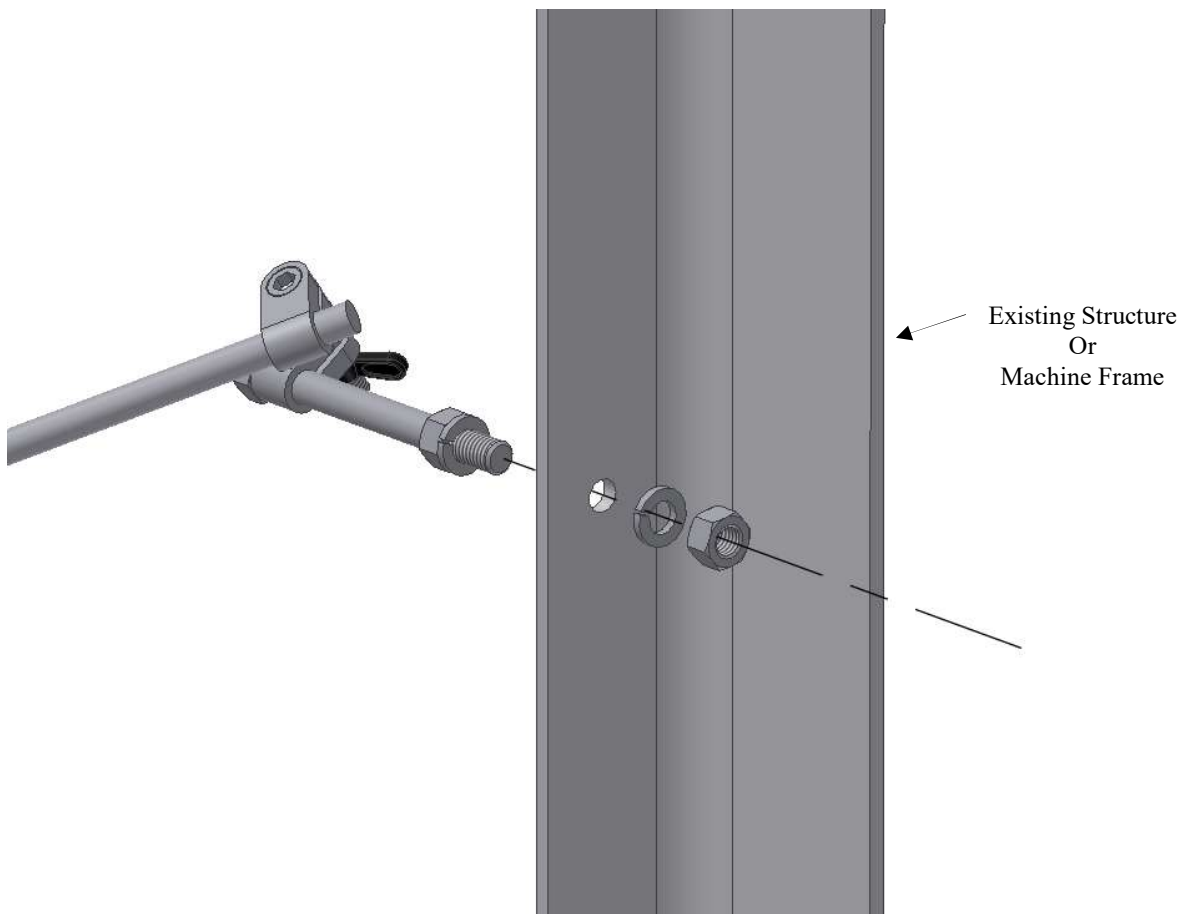

Figure 7 Bolt, Swivel Clamp and Extension Bar Assembly

TORQUE SPECIFICATIONS

All screws used to attach the bracket to the air knife should be tightened to 7.5 ft-lbs. On the 1/2" bolts such as the one that attaches the bracket to the swivel clamp, torque bolt to between 60-100 ft-lbs.

MAINTENANCE

Periodically check screws and clamps to make sure they remain tight.

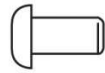
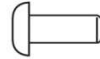
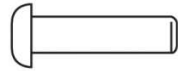
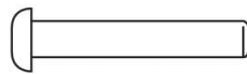
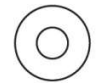
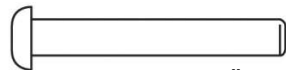
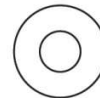
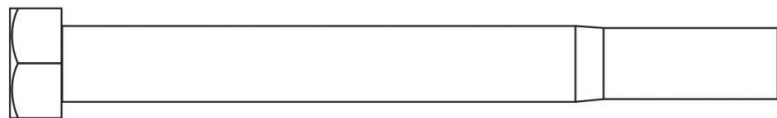
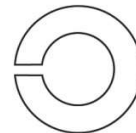
HARDWARE (SHOWN TO SCALE)**(3)** 1/4 - 20 x 1/2" BHCS**(3)** #10-24 x 1/2" BHCS**(3)** 1/4 - 20 x 1" BHCS**(3)** #10 - 24 x 3/4" BHCS**(3)** 1/4 - 20 x 1-1/2" BHCS**(3)** #10 Washer**(2)** 1/4 - 20 x 1-3/4" BHCS**(3)** 1/4" Washer**(2)** 1/2"-13 X 5" HEX BOLT**(4)** 1/2"-13 HEX NUT**(4)** 1/2" LOCK WASHER

If you have any questions or problems, please contact:

EPUTEC Drucklufttechnik GmbH

Haidenbucherstr. 1
86916 Kaufering
Phone: +49 8191 91 51 19 0
Fax: +49 8191 91 51 19 91
Email: info@eputec.de
Website: www.eputec.de

